

Shuffleboard Table Instructions

We want to extend a HUGE thank you for your purchase of a Shuffleboard Table! Included below is a detailed walk through of our installation instructions. The instructions are listed in order of assembly to make the setup as smooth as possible!

1. After unpacking, identify the following parts:

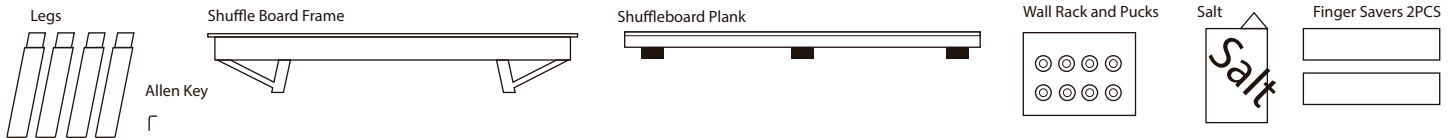

2. After all the parts are accounted for, take the legs and insert them into the shuffleboard frame.



3. Once the legs are installed, use the allen key provided to tighted down the set screws located on the inside of leg the extension on the the steel frame. We ship the table with the set screws in the steel base. Tightening down these screws insures that the legs stay securely in place, but **DO NOT** over tighten them.

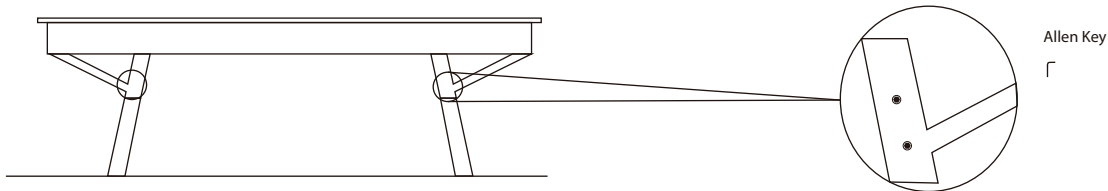

4. Awesome! Now that the legs are installed, make sure the table is level by adjusting the leg levelers if needed. **THE TABLE MUST BE PERFECTLY LEVEL BEFORE INSTERTING THE PLANK.**



5. Now that the table is level, it is time to install the plank. **FIRST**, place the 2 finger saver boards in the base, one on each end outside of the adjuster holes. This is to save your fingers from getting crushed by the heavy plank. The plank drops into the frame with the climatic adjusters fitting through the cutouts.

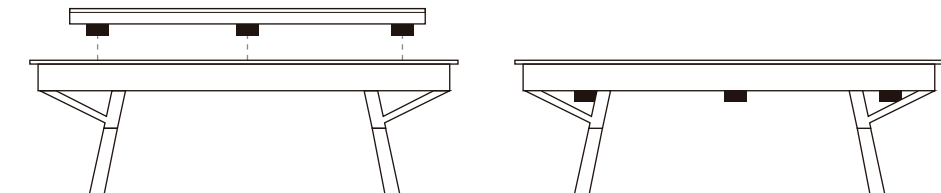

- To remove the finger savers under the plank, one person will need to get below the table and push up on the climatic adjusters while another person removes the finger saver and centers plank accordingly in the base. Then repeat on the other side.
- Now that the plank is installed, it is time to adjust the climatic adjusters to ensure the plank is ready for play.
NOTE: We make sure to level the plank before shipping.
If you are located outside of California, you likely will have to adjust the plank further.

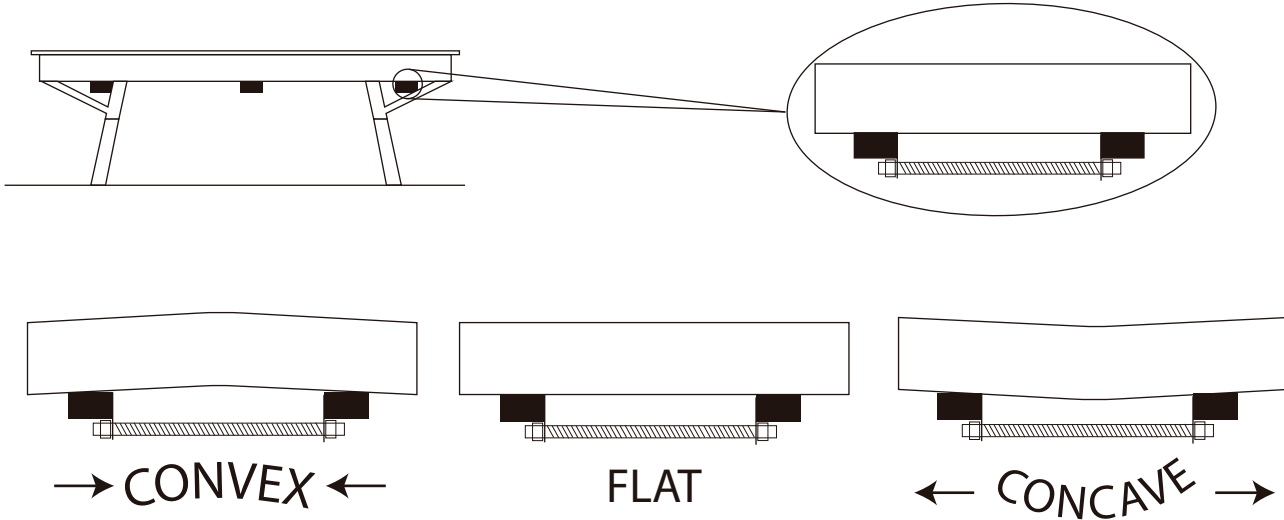

NOTE: Adjusting the Bolts inward will make the planks convex.
Adjusting the Bolts outward will make the planks concave.

- Use a level as you adjust the plank to create a slight concave. Once you can slide a piece a of paper (or thin business card) between the level and plank you have done it.
If you need further help on adjusting the plank, watch this video:
<https://www.youtube.com/watch?v=RF1Cb7iNXxM>

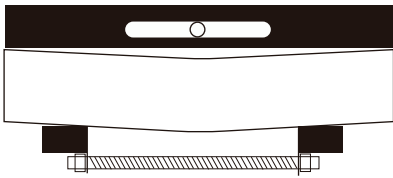

- Finally, after the table has been adjusted, evenly spread a layer of salt across the playing surface.
Sprinkle the salt from about 10- 12 inches above the table.

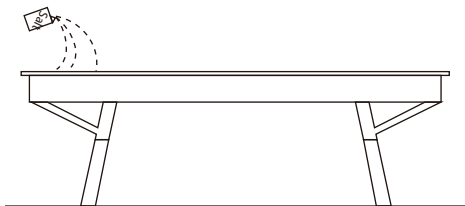

It is our goal that you are happy with your purchase, so please let us know if your buying experience was anything short of excellent. If you have any further questions feel free to email sean@seanwoolsey.com.
May your pucks slide fast and true!